

Humeral Nail System Procedural Steps



Table of Contents

Introduction.....	3
Instrumentation Set.....	8
Procedural Steps: Humeral Nail	10
Procedural Steps: Proximal Humeral Nail	13
Nail Cap Insertion and Nail Removal	18
Ordering Information.....	19

Introduction

The CarboFix™ Implants

The **CarboFix™** Humeral and Proximal Humeral Nails are made of longitudinal continuous carbon fibers reinforced Polymer (PEEK).

The Carbon Fibers are arranged in a unidirectional longitudinal orientation, as well as in a diagonal orientation, allowing multidirectional strength in all planes.

CarboFix™ is the first implant line to obtain FDA and CE clearance for orthopedic trauma implants made from carbon fiber composite material.

The Advantages of CarboFix™ Implants

Modulus of Elasticity

In comparison to metals, CarboFix™ implants have a modulus of elasticity closer to that of human cortical bone, theoretically lowering the risk of stress riser and secondary fractures.

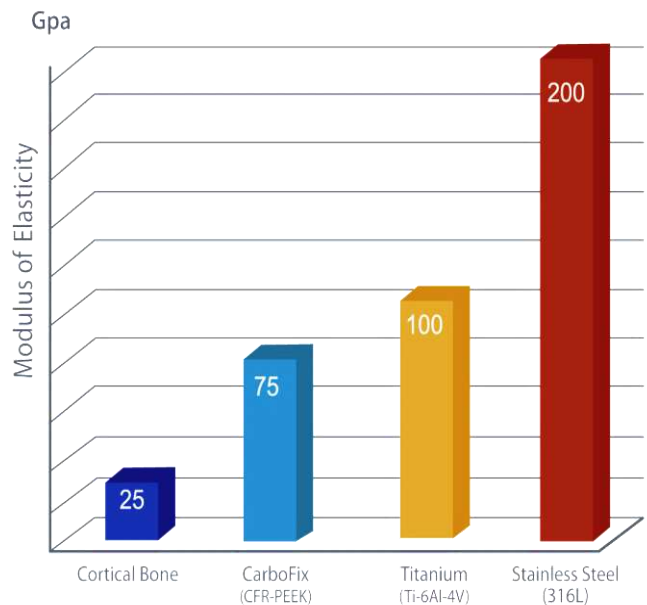

Fatigue Strength

Composite materials are known for their significant fatigue strength. Carbon fiber composite materials are currently being used in critical load bearing structures of commercial airliners (e.g. the wings of the Boeing 787 “Dreamliner”), high performance automobiles and now orthopedic trauma implants.

During fatigue testing the **CarboFix™** 8.5 mm nail withstood 4 million cycles without showing any sign of failure or damage to the nail, which is **4 times** the acceptance criteria for the applicable standard.

Radiolucency

CarboFix™ implants allow for unparalleled intraoperative and post operative imaging.



Metal Nail



CarboFix™ Nail - clear view of the fracture

CT & MRI Imaging

The CarboFix™ implants enable CT and MRI scans with minimal artifacts interference allowing for clear images of the surrounding tissues and the bone. This is clearly an advantage in monitoring fracture healing and pathological tissue.

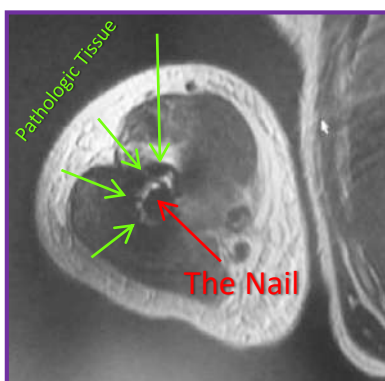

Titanium Rod Ø5mm in MRI field: demonstrates massive artifacts

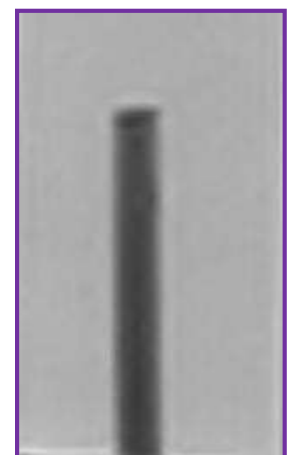

Carbon Fibers Rod Ø5mm in MRI field: no artifacts

The Implants

Two Humeral Nails designs are available:

❖ **CarboFix Humeral Nail** for the treatment of fractures of the humeral shaft.

❖ **CarboFix Proximal Humeral Nail** for the treatment of fractures of the proximal humerus.

Features:

- The Humeral Nail has a 5° proximal bend.
- The Proximal Humeral Nail includes four proximal screws providing multiple locking options in the head of the humerus.
- The proximal locking screws in the Humeral Nail are targeted and all locking screws (both proximal and distal) in the Proximal Humeral Nail are targeted.
- The screw holes have an inner thread for enhanced screw fixation to the nail.
- All nails are supplied sterile in various lengths

* For further information please refer to the product instructions for use.

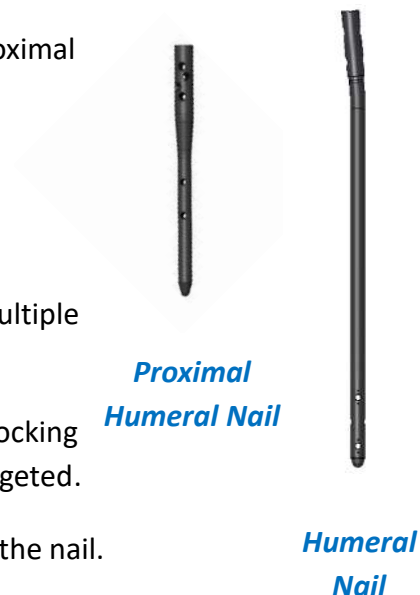

Nails' Design and Dimensions

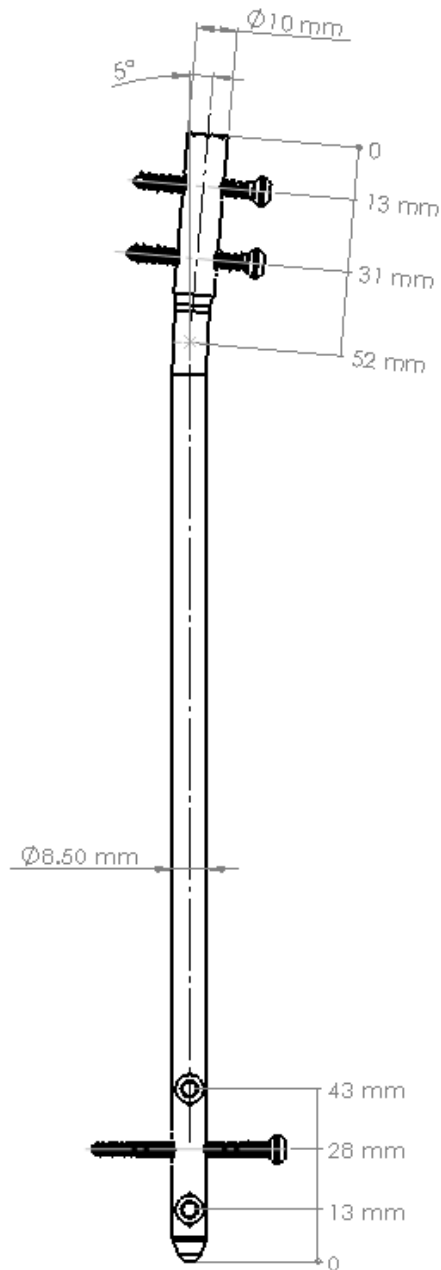

Humeral Nail
Ø 8.5 mm

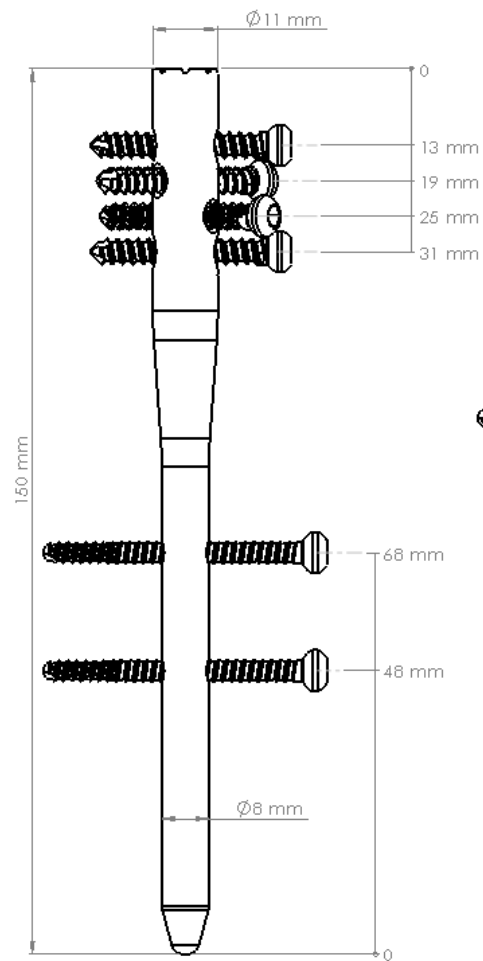

Proximal Humeral Nail

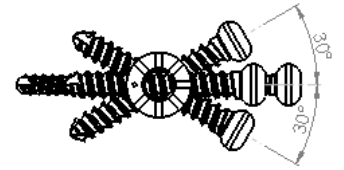

Available Nail Sizes

Type	Diameter (mm)	Proximal Diameter (mm)	Length (mm)
------	---------------	------------------------	-------------

Humeral Nail	8.5	10.0	180, 200, 220, 240, 260, 280
	7.5*	9.0	180, 200, 220, 240, 260, 280

* 7.5 mm nails are special order items.

Proximal Humeral Nail	8.0	11.0	150
-----------------------	-----	------	-----

Introduction

Radiopaque Markers

1. Radiopaque marker along the nail longitudinal axis enables nail visualization under fluoroscopy.
2. Marker at the nail proximal end of the nails indicating the terminal end (proximal end) of the nail.
3. Markers, which are located at both sides of each hole.
4. Nail Cap markers, embedded within the nail cap.

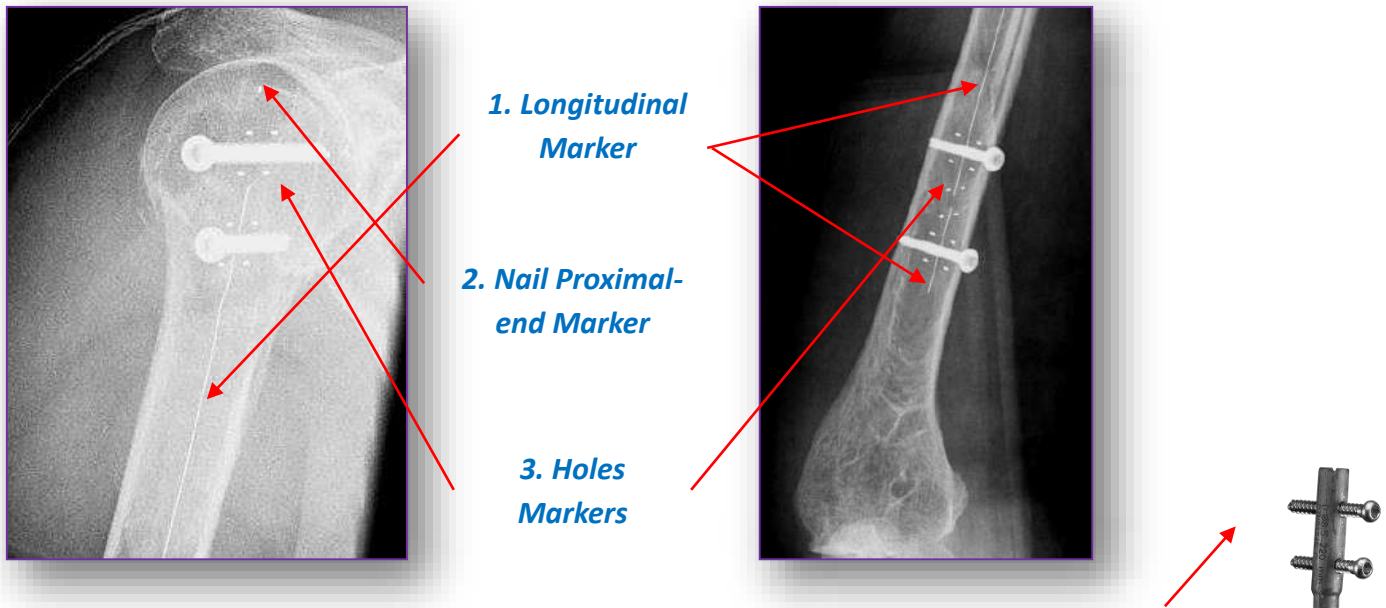

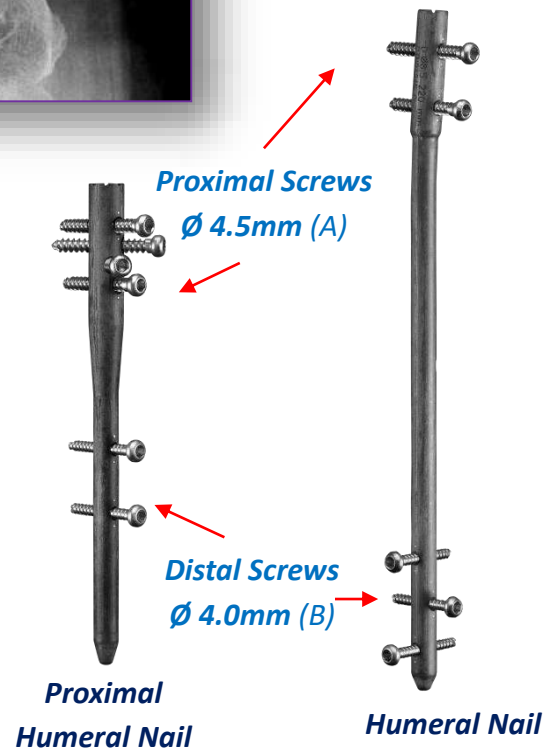

The Screws

1. **Proximal:** Two \varnothing 4.5mm(A) in the Humeral Nail & four in the Proximal Humeral Nail.
2. **Distal:** Three \varnothing 4.0mm Screws in the Humeral Nail and Two \varnothing 4.0mm Screws in the Proximal Humeral Nail (B).
3. All screws are provided non-sterile and are contained in the instrument tray.

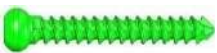

Available Screws

	Description	Diameter (mm)	Lengths (mm)	Screw/Drill Bit Marker Color	Drill Bit Diameter (mm)	
A	Proximal Screw, Titanium	4.5	28-56 (2.0mm increments)	Green	3.0	
B	Distal Screw, Titanium	4.0	22-36 (2.0mm increments)	Yellow	3.2	

Instrumentation Set

The instrumentation tray includes the instrumentation for both the **CarboFix Humeral Nail** and the **CarboFix Proximal Humeral Nail**.

Insertion Handle

Designed for nail insertion and as a guide for screw insertion.

The Insertion Handle has holes allowing for positioning of the guide sleeves:

- 2 holes marked as “**HN/PHN**” for targeting the proximal holes of both the Humeral and Proximal Humeral Nails.
- 2 holes marked as “**PHN**” for targeting the distal holes of the Proximal Humeral Nail



Proximal Aiming Arm

The Arm is connected to the Insertion Handle when the Proximal Humeral Nail is used.

It is targeting the proximal oblique holes of the Proximal Humeral Nail.



Nail Adapter

The Nail Adapter connects the proximal end of the Humeral and Proximal Humeral Nail to the Insertion Handle.

Nail Adapter Pin

The Nail Adapter Pin is used to tighten or loosen the Nail Adapter to the Humeral and Proximal Humeral Nail.

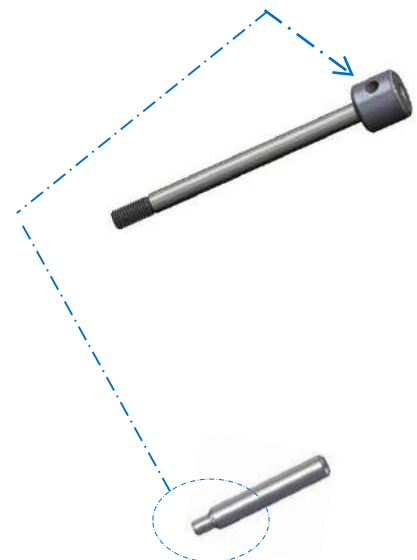

Inner Rod

The Inner Rod is inserted through the Nail Adapter and the Humeral and Proximal Humeral Nail at the proximal end. The Inner Rod is used to strengthen the connection between the nail and the Insertion Handle during implant insertion.

Guide Sleeve & Trocar

The Guide Sleeve creates a targeted pathway for locking the nail. The Trocar and Drill Sleeve are inserted through the Guide Sleeve.



Drill Sleeves

Targeted pathways for the following Drill Bits:

- Drill Sleeve 8.0/3.2 for 3.0mm & 3.2mm Drill Bits

*The drill bits are calibrated to measure against the Drill sleeve for appropriate screw length. Make sure that the drill sleeves and Guide sleeve are fully seated into the aiming arm for accurate measurement.



Drill Bits

There are two Drill Bits in the set:

- \varnothing 3.0mm Drill Bit for drilling the holes for the proximal screws (screw diameter 4.5mm). It is marked along its shaft for measuring the required proximal screw length. Marked **Green (A)**.
- \varnothing 3.2mm Drill Bit **Short** (L:180mm) for drilling the holes for the distal screws (screw diameter 4.0mm) for the Humeral Nail **(B)**.
- \varnothing 3.2mm Drill Bit **Long** (L:250mm) for drilling the holes for the distal screws (screw diameter 4.0mm) through the aiming arm for the Proximal Humeral nail. Marked **Blue (C)**.

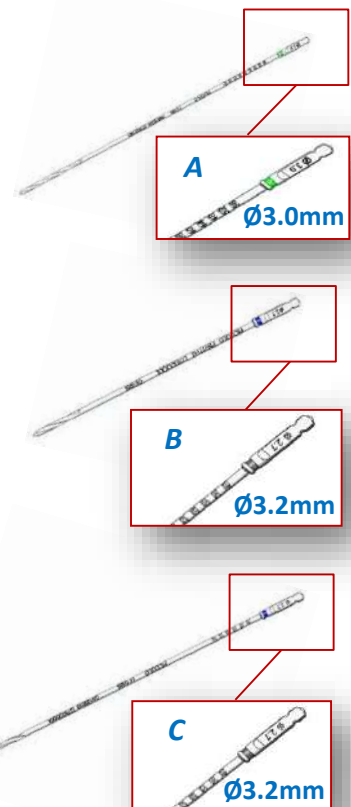

Free Hand Drill Sleeve

The Free Hand Drill Sleeve is a tissue protector for targeting the distal screw holes using the short \varnothing 3.2mm Drill Bit. The Free Hand Drill Sleeve is radiolucent.

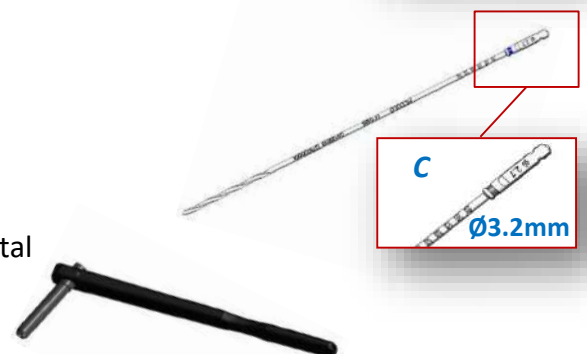

The Free Hand Drill Sleeve is located in the instrument tray lid

Depth Gauge

Designed to measure the required screw length.
The hook can be rotated according to surgeons preference. The hook's orientation is determined by the ball tip at the surgeon's end.

Screwdriver

Used to insert/remove the Screws and the Nail Cap.

Radiographic Ruler

Used to determine the required Nail diameter and length

Awl

Used to access the medullary canal for insertion of the Nail. The Awl is cannulated and can be positioned over a $\varnothing 3.2\text{mm}$ guide wire.

The Awl is located in the box lid

Mallet

The Mallet may be used during Nail insertion (the plastic side of the Mallet should be used to gently strike the Nail Inner Rod).

The Mallet is located in the box lid

Slide Hammer

It is used for Nail removal by connecting it to the Nail Removal Adapter. Alternatively, it may be used for nail insertion, In which case, it is connected to the Inner Rod.

Nail Removal Adapter

During Nail removal it is connected to the Nail's proximal end and to the Slide Hammer.



Procedural Steps

Humeral Nail

1. Use the **Awl** to gain access through the bone. Please note that the proximal diameter of the nail is 10.0mm.
Using the Awl over a $\varnothing 3.2$ mm K-wire is optional (A).
Antegrade approach is recommended

Measure the Humerus length and diameter using the **Radiographic Ruler**.

Choose the suitable Nail length according to the following table:

Humeral Nail Size Selection

Diameter (mm)	Proximal Diameter (mm)	Length (mm)
8.5	10.0	180, 200, 220, 240, 260, 280
7.5*	9.0	180, 200, 220, 240, 260, 280
* 7.5 mm nails are special order items.		

2. Insert the **Nail Adapter** into the **Handle**. (B).

Ensure to match the grooves or "teeth". Based on these grooves the nail can only be attached to the Handle in one orientation. (C).

Connect the Nail to the Handle by rotating the Nail Adapter clockwise.

Important: Only Hand tightening shall be performed.

If required, insert the **Nail Adapter Pin** into a proprietary hole in the Nail Adapter and tighten (D).

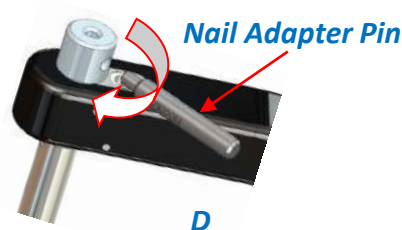

3. Insert the **Inner Rod** into the Nail Adapter and secure by rotating it clockwise (A).

4. Perform reaming using flexible reamers (not provided) to 1-1.5 mm greater than the implant diameter.

5. Partly insert the Nail into the humerus and perform reduction of the fracture under fluoroscopy; then advance the nail distally through the medullary canal.

If needed, use the Mallet or the Slide Hammer to advance the nail.

* The Slide Hammer can be connected to the Inner Rod only.



Important: Do not use excessive force. Use slight strokes only to position the nail. Do not use large rotational movements to insert the nail. Tap on the Inner Rod only.

During Nail insertion, ensure fracture reduction using fluoroscopy.

Proximal Screws Insertion

6. **Remove the Inner Rod.**

7. Place the Guide Sleeve with the Trocar inside the appropriate Handle hole (marked as HN/PHN) (B).

Make a small skin incision where trocar falls on the skin.

Advance the trocar tunneling through soft tissue up to bone.

Remove the Trocar.

8. Insert the Drill Sleeve into the Guide Sleeve.

Drill a hole through the proximal humerus for the Interlocking Screw.

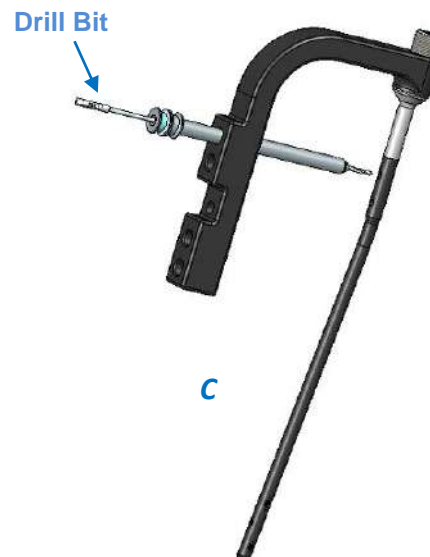
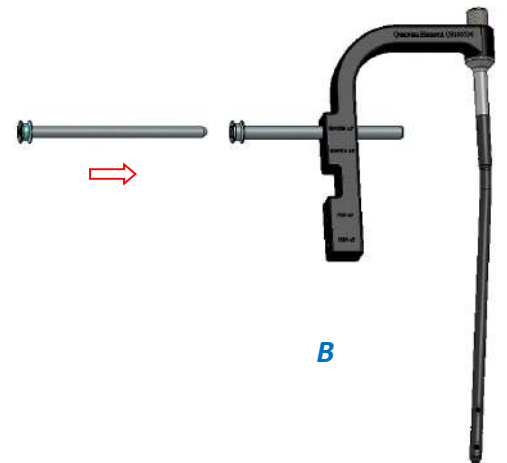

9. Measure the appropriate length of the Screw by the markings on the **Drill Bit** or by using the **Depth Gauge**.

Remove the **Drill Bit** and **Drill Sleeve**.

Insert the $\varnothing 4.5\text{mm}$ designated **Cancellous Bone Screw (Green)** using the **Screwdriver**.

Repeat sections 7 - 10 for the second proximal interlocking screw if desired.

Distal Screws Insertion

10. Distal drilling is performed free hand. The tantalum mini rods markers, located near the distal holes, assist in locating the center of the holes (B). Upon proper positioning, while the x-ray beam is perpendicular to the hole, the 2 radiopaque markers at each side of the hole should be aligned into a single dot. In proper positioning a single dot should be seen at each side of the hole (D).

Drill a hole for the Interlocking Screw through the **Free Hand Drill Sleeve** through both cortices, using the **Short $\varnothing 3.2\text{mm}$ Drill Bit**.

The Free Hand Drill Sleeve is radiolucent, and is used to position the Drill Bit in the desired trajectory, as well as protect the soft tissue during drilling (E).

Measure using the Depth Gauge and choose the appropriate length of the $\varnothing 4.0\text{mm}$ Screw (**Yellow**).

Insert the Screw by the **Screwdriver** & repeat the section 10 for the other hole/s as desired.

11. Disconnect the Handle from the Nail by screwing the Nail Adapter counter clockwise.



The Nail distal part & radiopaque markers under X-Ray

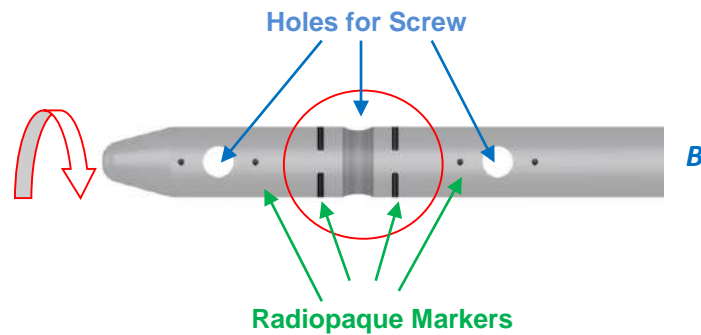

Incorrect Alignment of Markers for Distal Screws Insertion



Correct Alignment of Markers



Correct alignment



E

Procedural Steps

Proximal Humeral Nail

1. Use the **Awl** to gain access through the bone. Please note that the proximal diameter of the Nail is 11.0mm.
Using the Awl over a $\varnothing 3.2$ mm K-wire is optional (A).

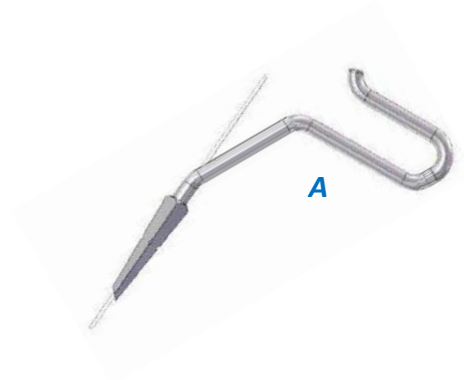

Proximal Humeral Nail Dimensions:

Diameter (mm)	Proximal Diameter (mm)	Length (mm)
8.0	11.0	150

2. Insert the **Nail Adapter** into the **Handle**. (B).
Ensure to match the grooves or “teeth”. Based on these grooves the nail can only be attached to the Handle in one orientation. (C).
Connect the Nail to the Handle by rotating the Nail Adapter clockwise.
Important: No instrumental tightening should be performed.
If required, insert the **Nail Adapter Pin** into a proprietary hole in the Nail Adapter and tighten (D).

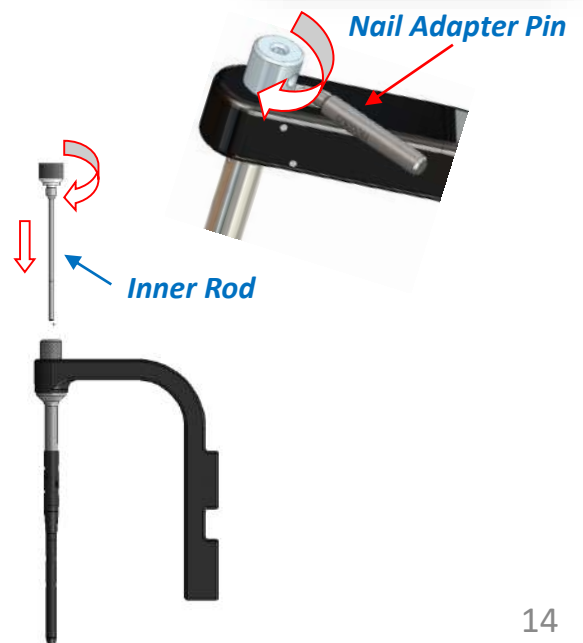

3. Insert the **Inner Rod** into the Nail Adapter and secure by rotating it clockwise (A).
4. **Perform Reaming if needed.** Perform reaming using flexible reamers (not provided) to 1-1.5 mm greater than the implant diameter.
5. Partially insert the nail into the humerus and perform reduction of the fracture under fluoroscopy; then advance the nail distally through the medullary canal.

If needed, use the Mallet or the Slide Hammer to advance the nail.

* The Slide Hammer can be connected to the Inner Rod only.



Important: Do not use excessive force. Use slight strokes only to position the Nail. Do not use large rotational movements to insert the nail. Tap on the Inner Rod only.

During Nail insertion, ensure fracture reduction using fluoroscopy.

6. Connect the **Proximal Aiming Arm** onto the **Handle**, and secure by using the **Arm Screw** (B).

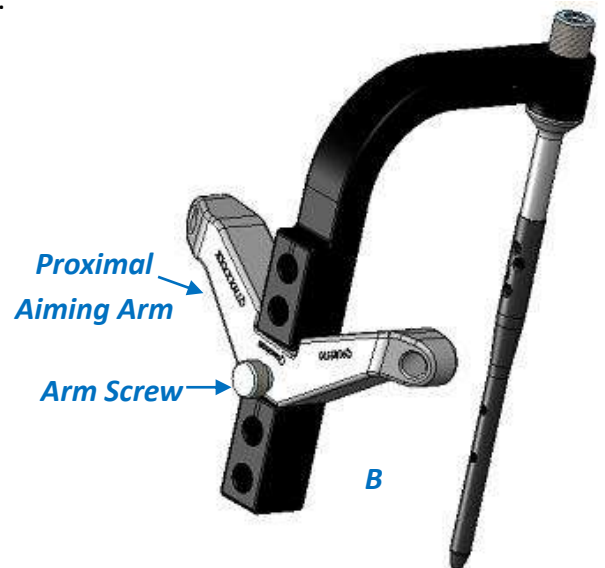

Proximal Screws Insertion

7. Remove the Inner Rod.

8. Place the Guide Sleeve with the Trocar inside the appropriate Handle hole (marked as HN/PHN) (A).

Make a small skin incision where trocar falls on the skin. Advance the trocar, tunneling through soft tissue up to bone.

Remove the Trocar.

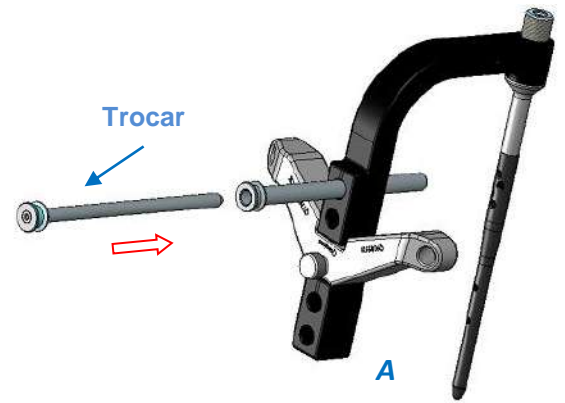

9. Insert the Drill Sleeve into the Guide Sleeve.

Use the 3.0mm Drill Bit (marked Green) to drill a hole into the humerus head for the Interlocking Screw (B).

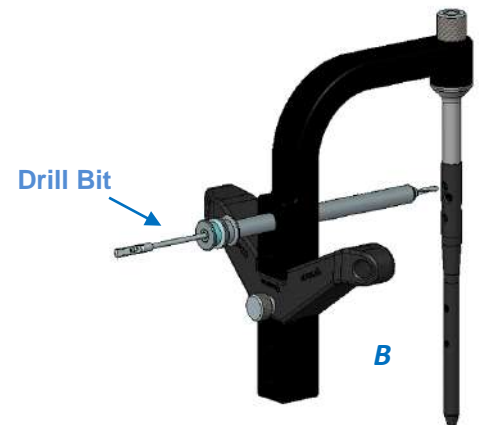

10. Measure the appropriate length of the Screw by the markings on the Drill Bit or by using the Depth Gauge. Remove the Drill Bit and Drill Sleeve.

Insert the \varnothing 4.5mm designated Cancellous Bone Screw (Green) using the Screwdriver.

Repeat sections 8 – 11 for the second proximal interlocking screw as well as the 2 oblique screws in the Proximal Aiming Arm (C).

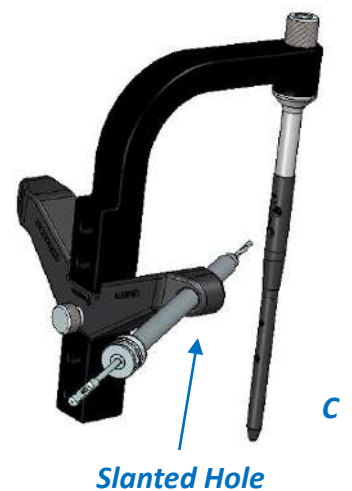

Distal Screws Insertion

11. Place the **Guide Sleeve** with the **Trocar** through the one of distal holes of the Insertion Handle (marked as PHN).

Make a small skin incision where trocar falls on the skin.
Advance the trocar tunneling through soft tissue up to bone.
Remove the Trocar.

12. Insert the **3.2 mm Drill Sleeve** (marked **Yellow**) through the Guide Sleeve (A).

Use the **Long 3.2mm Drill Bit** (marked **Yellow**) to drill a hole through both cortices.
Remove the Drill Bit and Sleeve.

13. Measure the appropriate length of the \varnothing 4.0mm Cortical Bone Screw with the **Depth Gauge**.
Insert the designated \varnothing 4.0mm Cortical Bone Screw (Marked **Yellow**) using the **Screwdriver**.

If desired, repeat sections 11 – 13 for the second distal hole as well.

14. Disconnect the Handle from the Nail by screwing the Nail Adapter counter clockwise.

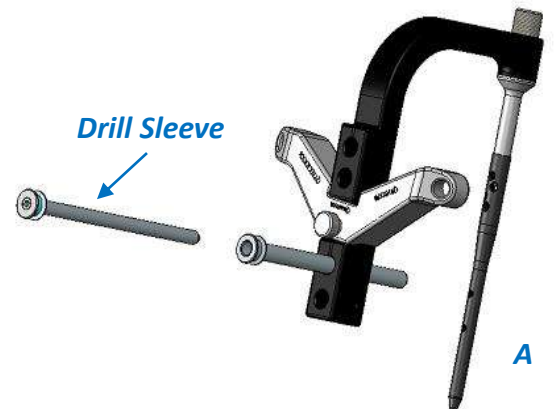

Nail Cap Insertion

The Nail Cap is supplied individually and packed sterile. When locked, the Nail Cap protrudes 4 mm proximally.

The Nail Cap is radiolucent; therefore two radiopaque markers are embedded at its proximal end, for visualization under fluoroscopy.

It is recommended to insert a Nail Cap for all Humeral Nail procedures to allow easy removal of the implant if required.

In order to insert the Nail Cap follow these steps:

1. Disconnect the Handle from the Nail by screwing the Nail Adapter counterclockwise.
2. Introduce the Nail Cap to the screwdriver and into the Nail's proximal end. Insert by rotating clockwise.



Nail Removal

1. Remove the **Nail Cap** and the Interlocking Screws by using the **Screwdriver**.
2. Screw the **Nail Removal Adapter** onto the nail's proximal end.
3. Connect the **Slide Hammer** to the Nail Removal Adapter.

Use light strokes of the Slide Hammer to remove the Nail from the bone.



Ordering Information

Humeral Nail

Cat. No.	Description	Diameter (mm)	Length (mm)	Proximal Dia. (mm)
4QHN85180	CarboFix Humeral Nail 8.5 180mm	8.5	180	10.0
4QHN85200	CarboFix Humeral Nail 8.5 200mm	8.5	200	10.0
4QHN85220	CarboFix Humeral Nail 8.5 220mm	8.5	220	10.0
4QHN85240	CarboFix Humeral Nail 8.5 240mm	8.5	240	10.0
4QHN85260	CarboFix Humeral Nail 8.5 260mm	8.5	260	10.0
4QHN85280	CarboFix Humeral Nail 8.5 280mm	8.5	280	10.0

Proximal Humeral Nail

Cat. No.	Description	Diameter (mm)	Length (mm)	Proximal Dia. (mm)
4QHNP8015	CarboFix Proximal Humeral Nail	8.0	150	11.0

Screws

Distal Ø 4.0 Titanium (Yellow)

Cat. No.	Description	Diameter (mm)	Length (mm)	No. Screws in Inst. Set
PCST40220	CarboFix Titanium Screw, 4.0mm, L22mm	4.0	22	3
PCST40240	CarboFix Titanium Screw, 4.0mm, L24mm	4.0	24	3
PCST40260	CarboFix Titanium Screw, 4.0mm, L26mm	4.0	26	5
PCST40280	CarboFix Titanium Screw, 4.0mm, L28mm	4.0	28	5
PCST40300	CarboFix Titanium Screw, 4.0mm, L30mm	4.0	30	5
PCST40320	CarboFix Titanium Screw, 4.0mm, L32mm	4.0	32	5
PCST40340	CarboFix Titanium Screw, 4.0mm, L34mm	4.0	34	5
PCST40360	CarboFix Titanium Screw, 4.0mm, L36mm	4.0	36	3

Proximal Ø 4.5 Titanium (Green)

Cat. No.	Description	Diameter (mm)	Length (mm)	No. Screws in Inst. Set
QCST4528	CarboFix Titanium Screw, 4.5mm, L28mm	4.5	28	4
QCST4530	CarboFix Titanium Screw, 4.5mm, L30mm	4.5	30	4
QCST4532	CarboFix Titanium Screw, 4.5mm, L32mm	4.5	32	4
QCST4534	CarboFix Titanium Screw, 4.5mm, L34mm	4.5	34	6
QCST4536	CarboFix Titanium Screw, 4.5mm, L36mm	4.5	36	6
QCST4538	CarboFix Titanium Screw, 4.5mm, L38mm	4.5	38	6
QCST4540	CarboFix Titanium Screw, 4.5mm, L40mm	4.5	40	6
QCST4542	CarboFix Titanium Screw, 4.5mm, L42mm	4.5	42	6
QCST4544	CarboFix Titanium Screw, 4.5mm, L44mm	4.5	44	6
QCST4546	CarboFix Titanium Screw, 4.5mm, L46mm	4.5	46	6
QCST4548	CarboFix Titanium Screw, 4.5mm, L48mm	4.5	48	4
QCST4550	CarboFix Titanium Screw, 4.5mm, L50mm	4.5	50	4
QCST4552	CarboFix Titanium Screw, 4.5mm, L52mm	4.5	52	4
QCST4554	CarboFix Titanium Screw, 4.5mm, L54mm	4.5	54	2
QCST4556	CarboFix Titanium Screw, 4.5mm, L56mm	4.5	56	2

Miscellaneous

Cat. No.	Description
PFT912260	Access Guide Wire Ø3.2mmX350mm, <i>Sterile & Single Use</i>
HN930235	Drill Bit Ø3.0X235mm, <i>Sterile & Single Use</i>
9205000	Drill Bit Ø3.2X250mm, <i>Sterile & Single Use</i>
PN932145US	Drill Bit Ø3.2X180mm, <i>Sterile & Single Use</i>
QHNC7000	CarboFix Humeral Nail Cap, <i>Sterile</i>
4QH910100	CarboFix HN/PHN Instrumentation Set (Not Including Screws)

Instrumentation Set Components

Cat. No.	Description
Q9106970	Sterilization Box
Q9105530	Handle
Q9105570	Proximal Aiming Arm
Q9105060	Nail Adapter
Q9105850	Inner Rod
Q9240390	Trocar 8.0 mm
Q9240020	Guide Sleeve 10.0/8.0 mm
4Q9106740	Drill Sleeve 8.0/3.2 mm
HN930235	Drill Bit 3.0x235 mm
9205000	Drill Bit 3.2x250 mm
PN932145US	Drill Bit 3.2x180 mm
PFT912020	Opening Pin
4Q9107000	Free Hand Drill Sleeve (carbon) 3.2mm
Q9104500	Screwdriver 3.5 mm
Q9105760	Slide Hammer
Q9105110	Mallet
Q9105100	Removal Adapter
Q9105000	Radiographic Ruler
Q9106690	Screw Depth Gauge
PFT912200	Awl

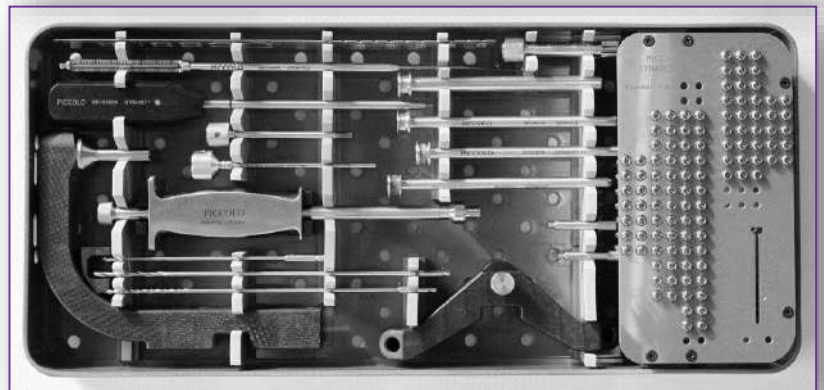
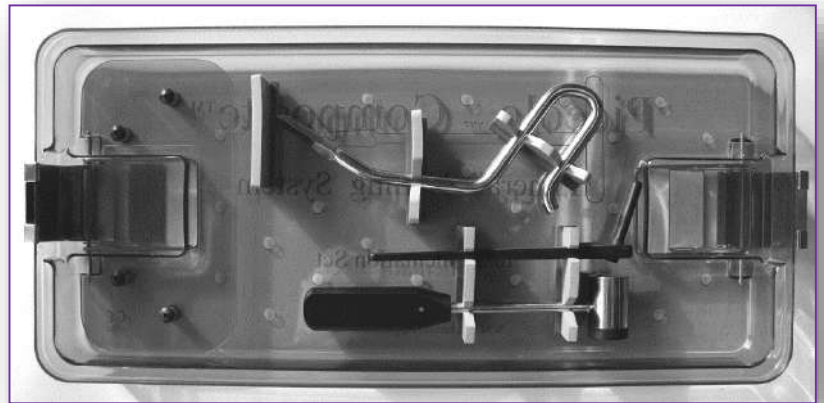

CarboFix Humeral Nail Instrumentation Set



www.carbo-fix.com

For detailed procedure, indications, contraindications, possible adverse event, warnings and precautions, refer to the Instructions for Use

Caution: In the U.S.A., federal law restricts this device to sale by or on the order of a physician.

MANUFACTURED BY:

CarboFix Orthopedics Ltd.
11 Ha'hoshlim St.,
Herzeliya 46724, Israel
Tel: +972-9-9511511
Fax: +972-9-9548939
E-Mail: info@carbo-fix.com

U.S.A. OFFICE:

CarboFix Orthopedics Inc.
7183-1 Beach Drive SW
Ocean Isle Beach, NC 28469, USA
Tel: 1-800-408-0120
E-Mail: usa@carbo-fix.com

EC AUTHORIZED REPRESENTATIVE:

MEDNET GmbH
Borkstrasse 10, 48163 Münster
Germany

Patents are pending



Ver.: 9.1.2019